

Contents

GROUP 11 - 11.1 - Domus Ducting Systems

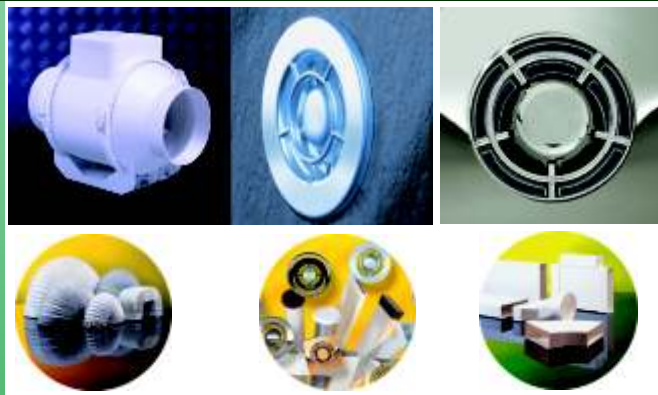
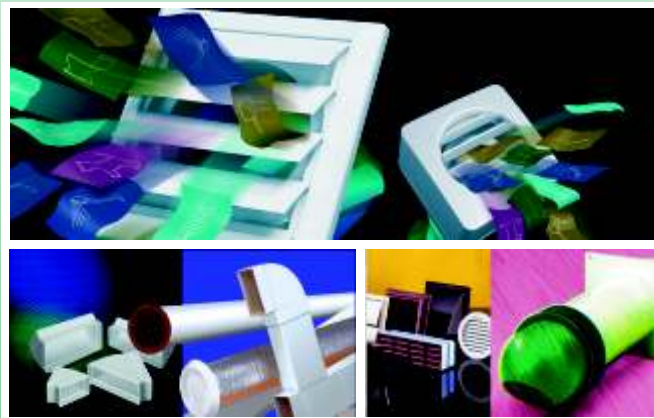

The Complete Modular Ducting System

SUPERTUBE 125

Supertube 125 is ideal for the ducting of all rangehoods and powerful fans. The airflow efficiency of Supertube 125 is maintained even on long ducting runs and can be used with appliances of high extraction rates.



EASIPIPE

EasiPipe round ducting is available in three diameters: 100, 125 and 150mm. EasiPipe is a multiapplication system and is ideal for larger fans, rangehoods, whole-house ventilation systems, stack ventilation and air conditioning. A round pipe system represents the most efficient air flow conduit as less air turbulence occurs.

HOSES & ACCESSORIES

Flexible hoses provide a solution to overcome situations where a rigid component cannot be installed. Manufactured in PVC self-extinguishing material or polyester coated aluminium for extra strength. Hoses are mainly for use with tumble dryers or when there is slow moving air. Round and rectangular hoses are available in sizes which are compatible with all our six ranges in various standard lengths.

A selection of accessories including hose connectors, clips and tape provide effective connections from flexible to rigid ducting.

Domus has a large range of round and rectangular PVC flexible hoses in various lengths that are compatible with System 100, Supertube125, MegaDuct 220, EasiPipe and ThermaPipe. Hose provides solutions to overcome situations where a rigid component cannot be installed.



WALL OUTLETS

Domus Ducting manufacture a comprehensive range of wall outlets, which are fully compatible with all Domus system configurations. A choice of three round spigots to fit all EasiPipe sizes and rectangular sockets for use with Supertube 125 are available. Wall outlets are manufactured in White UV stabilised colour finishes. There are various types of outlets for use in different situations.

KITS

A range of standard boxed kits is available providing a one-stop solution to many popular installation requirements. However, should these kits not provide the necessary products, special kits can be designed to meet the exact specification of the installation. All are packed in purpose made cartons.



Introduction

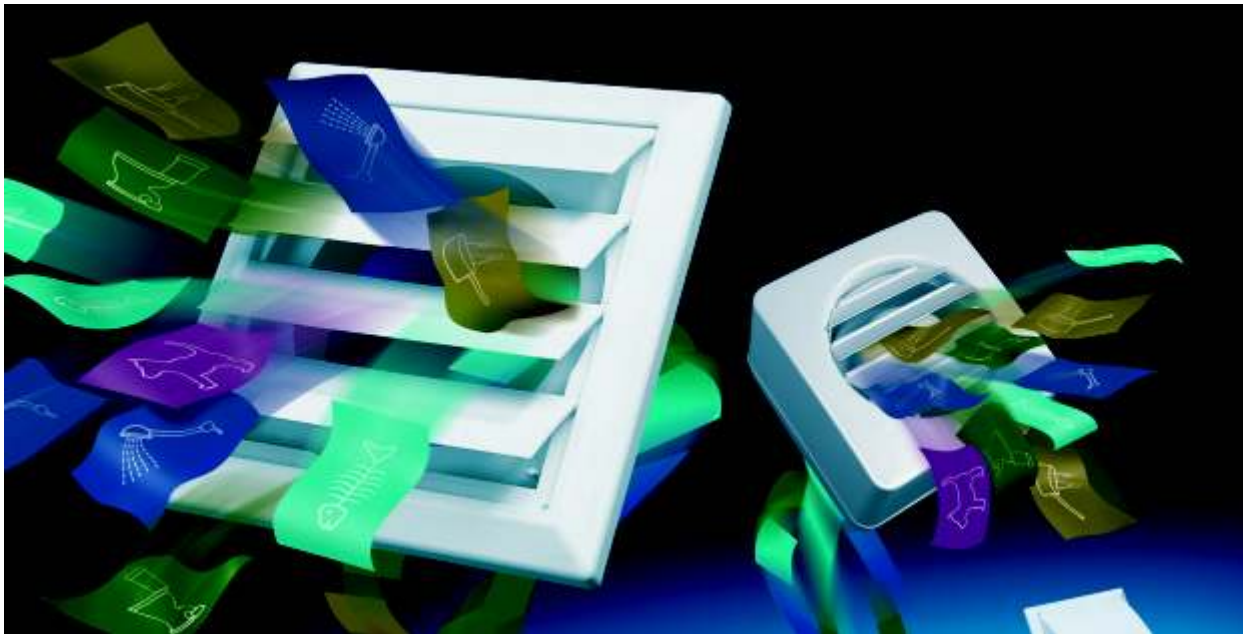

Domus Ducting specialises in the design and manufacture of modular system parts for the ventilation of domestic kitchens and bathrooms, light industrial and commercial premises.

The range includes flat channel ducting for installation in confined spaces and round systems for use where space is not a restriction and efficiency is the main concern.

The features of the Domus Range include:

- * Manufactured with flame retardant plastics to meet the relevant international standards. * Lightweight, with simple push-fit connections for quick installation. * Ducts are easily cut to length with a hacksaw.
- * Does not corrode, leading to a long life.
- * Recycled materials are used wherever possible.

SUPERTUBE 125

Ideal for the ducting of kitchen rangehoods and fans with 100, 125 or 150mm round exhaust spigots. Highly efficient even for long runs, and with appliances of a high extraction rate.

Supertube 125

Flat Channel outer dimensions are 204 x 60mm and fit into system parts sockets.

EASIPIPE

A round pipe is the most efficient airflow conduit as minimum air turbulence occurs. Consequently, Easipipe is ideal for larger fans, rangehoods, whole-house ventilation systems, stack ventilation and air-conditioning.

EasiPipe

System parts have spigots to fit inside 100, 125 and 150mm pipes.

Cross Section

11200 sq mm

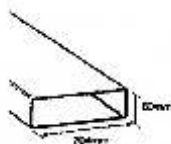

Cross Sections

- 7850 sq mm (100mm)
- 12266 sq mm (125mm)
- 17663 sq mm (150mm)



Introduction



Fittings.

Bends, flat channel, conversion pieces, air return boxes, flexible hoses and round and rectangular configuration wall outlets. For most standard applications, ready-boxed kits are available.

Standards and Materials.

All **DOMUS** system parts and channels are made of flame-retardant materials to conform to BS 476, DIN 4102/B 1, M1, UL94 V2 and AS 1668. **DOMUS** system parts are made from Polypropylene CP3457, HI Polystyrene CP3442 and PVC.

Design Considerations

Balanced Airflow. To obtain maximum air extraction efficiency, the air extracted must be replaced by means of back-flow ventilation. In particular, where an air extraction system is fitted in a building with an open flame appliance (eg. solid fuel stove, gas boiler, gas water heater, etc) great care must be taken to ensure that an amount of air back-flow is provided at least equal to the combined consumption and extraction rate of both appliances. Failure to provide this may lead to the reversal of flue gases into the room due to the power of the extraction device (eg. Rangehood) - this can cause carbon-monoxide poisoning.

Rangehoods. Use Supertube 125 or EasiPipe where possible, for maximum performance and reduced motor noise. Flexible hose provides a useful solution to odd angles and awkward configurations, but its use should be kept to minimum. Always install flexible hose with the wire helix pulled taut to minimise pressure loss and reduced performance.

Tumble Dryers. Only round flexible hose is suitable for tumble dryers. The duct run should be kept as short as possible and must not exceed 2.5m.

Extract Fan Limitations. Centrifugal Fans, whether for kitchen or bathroom air extraction, are a must with duct work. Only centrifugal fans will provide the pressure to achieve satisfactory results through the ducting run. Axial Fans do not provide any discernible pressure and such fans must not be used with ducts in excess of a wall thickness.

Services. For advice on applications of **DOMUS** modular ventilation ducting, please contact our Head Office.

Frequently Asked Questions ???**What is a DOMUS Flat Channel ?**

Flat Channel is a smooth bore rectangular section duct which can be concealed behind a kitchen cabinet cornice or in a ceiling void.

Are there different sizes of DOMUS Flat Channel ?

Supertube 205 x 60mm.

How would you describe its best use ?

Supertube is a high volume duct for rangehoods, extraction fans and heat recovery systems.

How does the Flat Channel connect up and terminate ?

DOMUS Supertube system is modular. There are many types of wall outlets to suit each application and a range of system parts to connect the Flat Channel with the appliance and the wall outlet.

Are there types of Flat Channel systems other than DOMUS ?

Yes, there is a flat Channel of a size 225mm x 25mm which is a high aspect ratio which may lead to clogging and fan failure.

What is an aspect ratio ?

This is a ratio between height and width of a duct. The squarer the profile of the channel (low ratio) the better the airflow. High aspect ratios have high resistance and reduce performance. **DOMUS** Supertube is low enough for easy concealment without sacrificing performance.

How easy is it to cut DOMUS Flat Channel to size ?

This is very easily achieved with a Hacksaw, as **DOMUS** Flat Channel is made of PVC. Galvanised channel is more difficult to cut to size and to manipulate in restricted spaces.

Why can I not use Flexible Hose throughout?

Flexible hose is ideal for short and awkward connections and to get around obstructions but the wire helix causes friction and turbulence, reducing performance. To minimise this flexible hose should always be kept as taut as possible. **NB: Under normal conditions, 1m of flexible hose has the same resistance as 5m of flat channel.**

How safe is the DOMUS Modular System ?

All **DOMUS** system parts and channel are made of flame-retardant material according to BS 476 (Fire Tests on Building Materials and Structures) as well as DIN 4102/B 1 and UL94 V2. The internal mouldings of fans and rangehoods are usually made to the same specification.

Why do some rangehoods make a booming noise, particularly when running at top speed ?

There can be two reasons. The first is the choice of duct which can be too small, of high aspect ratio or inefficient flexible hose. Replacement of the ductwork with **DOMUS** Supertube will usually reduce the noise level.

The other reason is lack of return air to replace the extracted air (refer to next question and answer). It must be kept in mind that air handling will always be audible.

We Answer Your Questions ???

Why do my kitchen windows steam up even with the rangehood running?

A rangehood extracts air causing the pressure in the room to drop if air is not replaced. Lack of air supply causes the windows to mist up and also increases the motor noise as the rangehood has to work so much harder. To remedy this, the air flow must be balanced.

How do I balance the air flow ?

A **DOMUS** air return box should be fitted into an outside wall of the kitchen. This can be active or passive. The active air box is fitted with a fan motor wired into the rangehood motor switch. It will blow in fresh air whilst the rangehood is running. A passive box reacts to the pressure differential between the outside and the inside of the house and allows air to pass inside when the air pressure drops, ie, when the rangehood is turned on.

NOTE: To maintain the level of comfort the quantity of air brought in from outside should not exceed 20 to 25% of the extraction rate. The remainder of the required replacement air should be drawn as air leakage from the rest of the house, via, door ventilators fitted into the kitchen door (top and bottom of the door).

WARNING: Open flued appliances such as an Aga cooker, gas fired hot water appliance, etc maintain combustion by burning air from the kitchen. A rangehood extracting air from the kitchen without air backflow can starve the appliance of oxygen and even cause reversal of flue gases.

What precautions must I take if there is an open flued appliance in the kitchen?

If an open flued appliance is unavoidable the extraction appliance and its air supply vent(s) must conform to building regulations and a BS5440 product spillage test must be undertaken with the extracting appliance in operation. An open fire place in the lounge, which may not be adjacent to the kitchen, does nevertheless require a BS5440 test as any open flue appliance in the dwelling must be taken into account when installing a rangehood.

Gas hobs, gas ovens and balanced-flue (room sealed) appliances are exempt from this test. Balanced-flue boilers have no permanently open air leakage and are therefore not affected by extraction.

Where can I obtain DOMUS Modular Ducting System parts and flat channel ?

Ask us for your nearest stockist by phone, fax or by writing to our head office.

What Type of fan should be used ?

There are basically two types of ventilation fan:

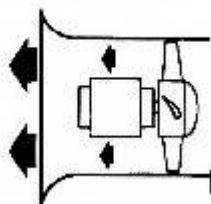

A. Axial Fan - the air is expelled approximately parallel to the axis of the fan. Axial Fans build up little air pressure and are unsuitable for ducted installations except where the duct is very short and WITHOUT BENDS, eg. traversing a cavity wall. The maximum length of the duct should not exceed 350mm with this type of fan.

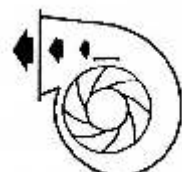

B. Radial or Centrifugal Fans - the air is expelled at approximately 90 degrees to the axis of the fan. Radial Fans are aided by centrifugal force, created by the impeller and build-up of good air pressure characteristics for ducted air handling. This allows even quite long ductwork (as may be required for internal bathrooms or toilets) but still provides good ventilation.

Application of Easipipe Round Modular Ducting System

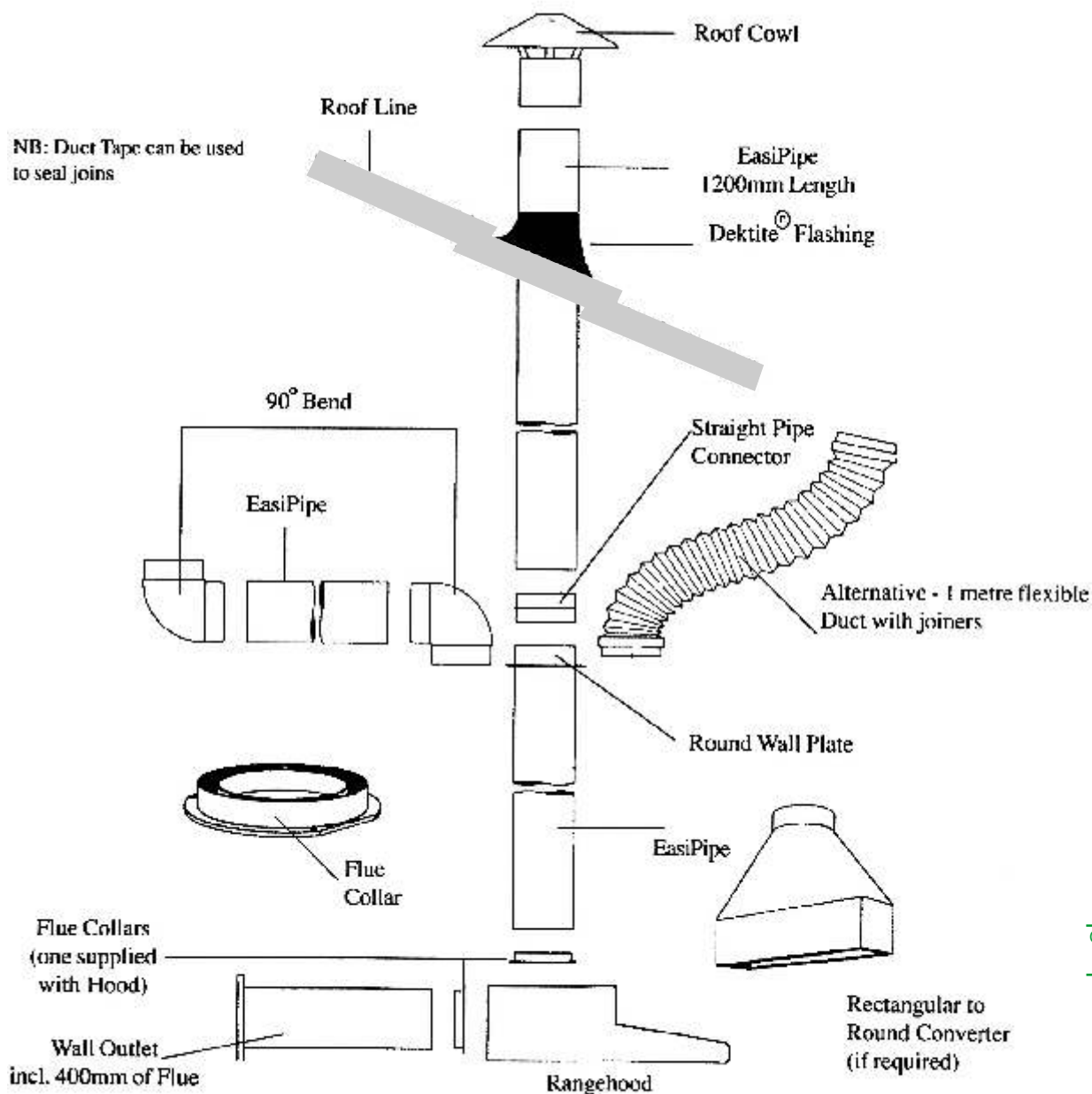

Modular Ducting Systems

Group 11
11.1

Typical Rangehood Ducting Systems Information

Advice on Air Flow

Do not forget that a rangehood operating in extraction mode physically removes air from the kitchen. Removing such a large body of air is only possible if there is enough backflow of air available. In today's well-insulated homes there is not enough air leakage available to achieve the required backflow.

A solution is to **balance the air flow** by using a **return air box** on an external wall (preferably opposite the extraction unit).

Technical Advice and Design Guidance

Contained within the product catalogue is a selection of our popular kits, however, boxed kits can be created to order using any component from the Domus Range.

Illustrated below are some examples of typical ducting configurations used to duct from a rangehood.

Typical Rangehood Ducting Systems

General Pointers on Fan Setting and Back Flow

In all installations mount the extraction unit at the furthest point from the air inlet point and at as high a level as possible.

Do not position a fan in locations where the temperature is likely to exceed 40' C.

Ensure there is sufficient air back flow when installing an extraction unit in a dwelling where there are open flued appliances.

Bathroom installations must not allow the fan to be in reach of the person using the bath or shower

With duct lengths in excess of one metre, a centrifugal fan must always be used.

Ducting System Performance

Performance is greatly affected by both the length of the ducting and the number of bends contained in the run.

This can be measured by calculating the amount of pressure loss (measured in pascals) in various products contained within a duct run. Each product in the Domus Range has a Pascal (Pa) value, a list of which is shown in the table over the page.

The following is an example of how to calculate the amount of pressure loss in a typical kitchen installation.

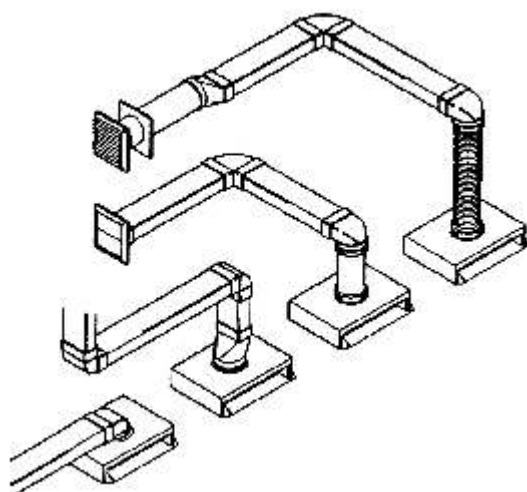

SYSTEM CONFIGURATION		
Product	Description	Pa.
2 x 515	3m Flat Channel	7.8
520	Flat Channel Connector	1.5
560	Vertical 90 Bend	4.3
501	Brick Size Louvre with Damper	75.8
Total		129.4



For this example the performance of the fan should exceed 130pa at an airflow rate of 60 litres per second.

Pressure Loss Characteristics of Domus Ducting Components

CODE	DESCRIPTION	PRESSURE LOSS (Pa)		
		15L.s	30L.s	60L.s
SUPERTUBE 125				
515	Flat Channel 1.5m	0.5	1.5	5.2
520	Flat Channel Connector	0.1	0.4	1.5
527	Flat Channel Connector with Damper	21.9	41.1	43.2
545	Horizontal Adjustable Bend	0.7	2.1	6.3
550	Horizontal Bend	2.1	8.4	33.7
560	Vertical Bend	2.6	10.8	44.3
440	Elbow Bend with 100mm Connector	1.4	5.3	19.9
540	Elbow Bend with 125mm Connector	1.7	6.9	27.1
640	Elbow Bend with 150mm Connector	1.8	7.4	29.8
570	Round Rectangular Adapter	0.7	2.9	11.5
EASIPIPE 100				
1150-4	100mm Internal Dia. Rigid Pipe	0.5	1.4	3.1
490	Right Angle Bend	5.6	21.1	80.1
491	45° Bend	2.1	8.2	31.4
493	Straight Connector	0.9	4.2	20.4
494	Straight Connector with Damper	25	44.9	101.6
EASIPIPE 125				
1150-5	125mm Internal Dia Round Pipe 1m	0.2	0.7	1.9
590	Right Angle Bend	2	8.4	34.9
593	Straight Connector	0.2	0.9	4.3
594	Straight Connector with Damper	18.3	31.5	61.7
119	Circular Reducer 125-100mm	1.5	5.9	24
119 & 593	Reducer with Connector	1.6	6.2	24.2
EASIPIPE 150				
1150-6	Round Pipe 150mm Internal Dia	0.1	0.4	1.2
690	Right Angle Bend	1	4.2	18.2
693	Straight Connector	0.1	0.2	1.1
694	Straight Connector with damper	13.6	23.5	43.6
118	Circular Reducer 150-125mm	0.6	2.2	8.8
WALL OUTLETS & GRILLES				
4900	Gravity Flap Outlet, Round	9.2	10.8	11.4
4901	Gravity Flap Outlet, Rectangular	13.2	11	11.8
4902	Cowled Outlet, Round	6.7	12.5	41.6
4904	Louvred Grill, Round	2	7.9	30.4
4994	Louvred Grill, with Internal Damper	19.8	36.6	96
104	Louvred Grill with Flyscreen, Round	14.9	55.8	209.3
104	Louvred Grill without Flyscreen, Round	8.3	31.2	117.3
5900	Gravity Flap Outlet, Round	6.7	9.9	12.7
5904	Louvred Grill, Round	0.6	2.1	7.7
F5904	Louvred Grill with Flyscreen, Round	2	7.1	24.6
506	Gravity Flap Outlet, Round	7.1	9.3	11.1
502	Cowled Outlet, Round	6.7	12.4	36.3
504	Louvred Grill with Flyscreen	5.5	21	80
500	Louvred Grill with Internal Damper	19.8	32.4	73.2
6900	Gravity Flap Outlet, Round	5.9	8.5	11.4
6904	Louvred Grill, Round	0.5	1.8	6.3
F6904	Louvred Grill with Flyscreen, Round	1.6	5.2	17.4
501	Brick Size Louvre with damper	16.4	23.8	75.8
501	Brick Size Louvre no damper	4	15.6	59.9
4804	Round Louvred Grill	13.3	53	211.3
F4804	Round Louvred Grill with Flyscreen	21.5	86.4	346.5

NB: Although every effort has been made to ensure that the above figures are correct, the information should act as a guide only. It is the responsibility of the designer to ensure that the figures meet their requirements.

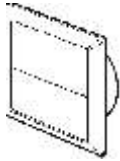
Wall Outlets and Ventilators

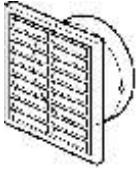
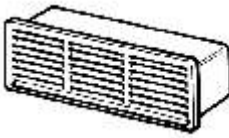
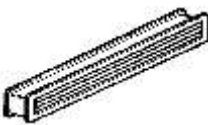



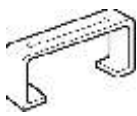
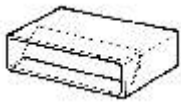
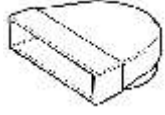
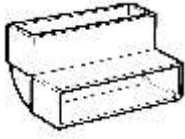

	Description	Tekform Part No.	Dimensions	Std Pack
	Wall Outlet with Gravity Flaps	D4900WH D5900WH D6900WH	Ø 100 □ 154 x 154 Ø 125 □ 200 x 200 Ø 150 □ 200 x 200	20 20 20
	Louvred Grill with Flyscreen	DF4904WH DF5904WH DF6904WH	Ø 100 □ 154 X 154 Ø 125 □ 200 X 200 Ø 150 □ 200 X 200	20 20 20
	Wall Outlet with Damper	D500WH	Ø 125 □ 183 X 183	10
	Brick Size Wall Outlet	D501WH	□ 201 x 57	20
	Internal Door Ventilator	D145WH	Cut Out Size 430 x 77	1

Supertube 125 Flat Modular Ducting

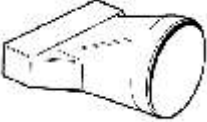
	Description	Tekform Part No.	Dimensions	Std Pack
	Flat Channel	D515WH	□ 204 x 60 L1500	10
	Flat Channel Clip	D122-5WH	□ 204 x 60	10
	Flat Channel Connector	D520WH	■ 204 x 60	10
	Flat Channel Connector with Damper	D527WH	■ 204 x 60	10
	Elbow Bend	D440WH	Ø 100 ■ 204 x 60	10
		D540WH	Ø 125 ■ 204 x 60	10
		D640WH	Ø 150 ■ 204 x 60	10
	Vertical 90° Bend	D560WH	□ 204 x 60	10

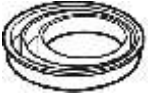

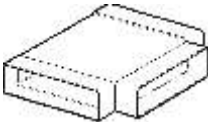
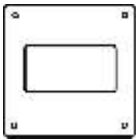
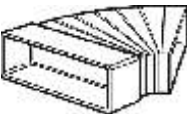

Key: L = length Ø□ = Outer Dimensions ●■ = Inner Dimensions - - - = Adjustable to-from

System Parts Flexible Hose and Air Supply Kits

	Description	Tekform Part No.	Dimensions	Std Pack
	Adapter	D570WH	Ø 125 ■ 204 x 60	10
	Adapter to Converter 125mm x 100mm	D544WH	Ø 129 Ø 125 Ø 100	1
	Adapter with offset centres for Art No 604	D644WH	Ø 145 Ø 125 Ø 100	1
	Horizontal 90° Bend	D550WH	■ 204 x 60	10
	Horizontal T Piece	D582WH	■ 204 x 60	10
	Rectangle Wall Plate	D115-5WH	■ 205 x 61 □ 262 x 118	1
	Adjustable Horizontal Bend	D545WH	■ 204 x 60 □ 201 x 57 3.75°--- 48.75°	10
	Flat Channel End Cap	D518WH		10

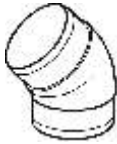
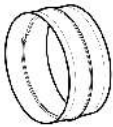
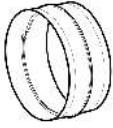
Key: L = length Ø□ = Outer Dimensions ●■ = Inner Dimensions - - - = Adjustable to-from

Easypipe Round Modular Ducting







	Description	Tekform Part No.	Dimensions	Std Pack
	Right Angle Bend	D490WH D590WH D690WH	Ø 100 Ø 125 Ø 150	10 10 10
	45° Bend	D491WH	Ø 100	10
	Straight Pipe Connector	D493WH D593WH D693WH	Ø 100 Ø 125 Ø 150	10 10 10
	Straight Pipe Connector with Damper Valve	D494WH D594WH D694WH	Ø 100 Ø 125 Ø 150	10 10 10
	Dektite® Tile Flashing on Lead	DF104G	● 75 — ● 160	10
	Dektite® Tile Flashing on Lead	DTFL104G	● 75 — ● 160	10
	China Hat Roof Cowl	D2503 D2505 D2507	● 100 ● 125 ● 150	1 1 1

Modular Ducting Systems

Group 11
11.1

Key: L = length Ø□ = Outer Dimensions ●■ = Inner Dimensions - - - = Adjustable to-from

System Parts Flexible Hose and Air Supply Kits







	Description	Tekform Part No.	Dimensions	Std Pack
	Straight Pipe Connector with Damper Valve & Wall Plate	D495WH D595WH D695WH	Ø 100 Ø 125 Ø 150	10 10 10
	Pipe Fastner	D496WH D596WH D696WH	Ø 100 Ø 125 Ø 150	10 10 10
	Round Pipe	DP53004 DP53412 DP1-1500 D1100-6WH	● 125 L 400 ● 125 L 1200 ● 100 L 1500 ● 150 L 1000	10 10 10 10
	Rectangle Flexible Hose	D533WH	■ 122 x 64 L3000	1
	Round Polyester Coated Aluminium Hose	D310WH D311WH D561WH	● 102 L1000 ● 102 L1000 ● 127 L1000	1 10 10
	Round Nude Aluminium Hose	D09043 D09046 D09053 D93063	● 102 L3000 ● 102 L6000 ● 127 L3000 ● 150 L3000	2 1 2 2

Modular Ducting Systems

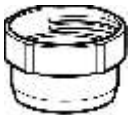
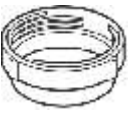
Group 11
11.1

Key: L = length Ø□ = Outer Dimensions ●■ = Inner Dimensions - - - = Adjustable to-from

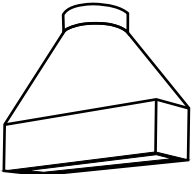
Pipe and Hose Accessories

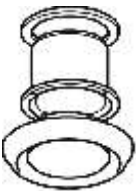
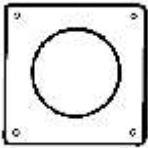
	Description	Tekform Part No.	Dimensions	Std Pack
	Threaded Hose Connector with Spigot	D124-4WH	□ 100	10
	Threaded Hose Connector with Socket	D126-4WH D126-5WH D126-6WH	■ 100 ■ 125 ■ 150	10 10 10
	Cable Tie	D125-CT	● 150	25
	PVC Duct Sealing Tape	D123-4WH	4.6m	1
	Gasket	DE6987	20m Roll	1
	Sheet Metal Converters Universal Chateau Mistral Qasair Robin Hood Torin Westinghouse	D571-UNI D571-CHT D571-MST D571-QSR D571-RBH D571-TRN D571-WTH	Ø 125 130 X 290 H 115 Ø 125 95 X 284 H 180 Ø 125 85 X 250 H 180 Ø 125 110 X 235 H 180 Ø 125 95 X 340 H 180 Ø 125 49 X 284 H 180 Ø 125 85 X 295 H 180	1 1 1 1 1 1 1
	Air Extract or Supply Valve to fit Pipe	D136-4WH D136-5WH D136-6WH	Ø 100 Ø 125 Ø 150	8 8 8
	Air Extract Valves with Ceiling Fitting	D136-24WH D136-25WH D136-26WH	Ø 100 Ø 125 Ø 150	10 10 10
	Round Wall Plate	D114-4WH D114-5WH D114-6WH	Ø 100 - 154 x 154 Ø 100 - 170 x 170 Ø 100 - 205 x 205	10 10 10

Modular Ducting Systems

Group 11
11.1

All Supertube 125 long Kits can be connected to 100mm, 125mm or 150mm Spigots

Modular Ducting Kits

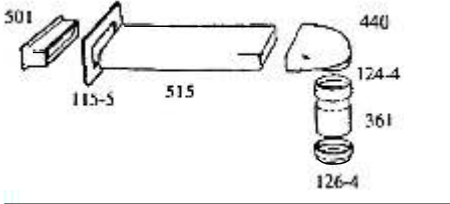
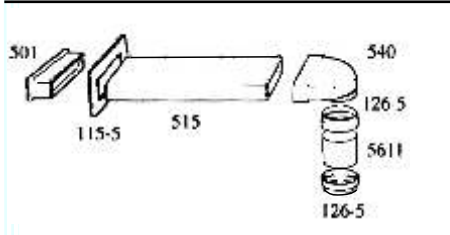
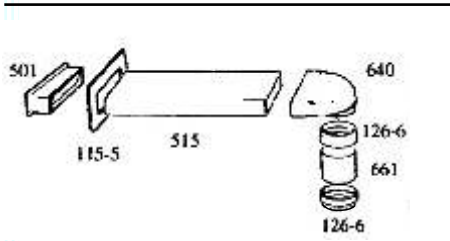
	Description	Tekform Kit No.	Std Pack
	<p>Supertube 125 Ducting Kit for 100m Diameter</p>	<p>DK220-4WH</p>	<p>1</p>
	<p>Supertube 125 Ducting Kit for 125m Diameter</p>	<p>DK220-5WH</p>	<p>1</p>
	<p>Supertube 125 Ducting Kit for 150m Diameter</p>	<p>DK220-6WH</p>	<p>1</p>

All Supertube 125 long Kits can be connected to 100mm, 125mm or 150mm Spigots

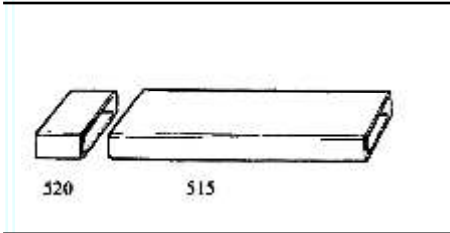
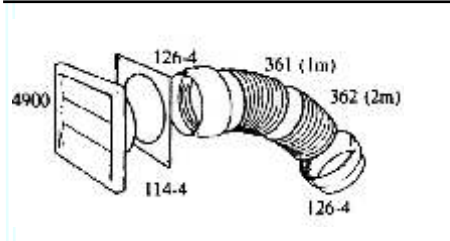
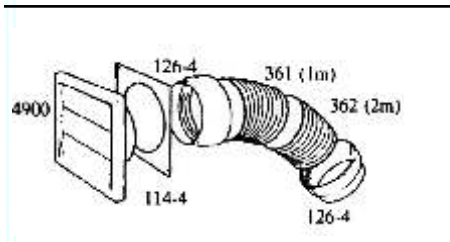
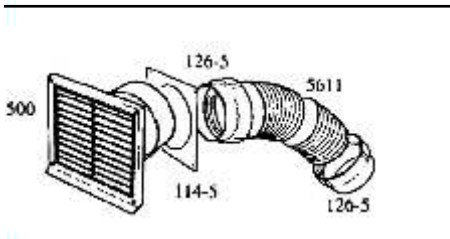
	<p>Supertube Flat Channel Rangehood Ducting Extension Kit</p>	<p>DK220-EWH</p>	<p>1</p>
	<p>Flexible Hose Ducting Kit for Tumble Dryers</p> <p>As above with 2000mm Hose</p>	<p>DK205WH DK210WH</p>	<p>1</p>
	<p>Flexible Hose Ducting Kit for Rear Ducting 100mm</p>	<p>DK206WH</p>	<p>1</p>
	<p>Flexible Hose Ducting Kit for Rear Ducting 125mm</p>	<p>DK215WH</p>	<p>1</p>

The kits illustrated are a popular selection, products can be assembled in kit form to meet customer's specific requirements