

Contents:

GROUP 15 - 15.1 - Router Bits

15.2 - Drill Bits / Saw Blades / Accessories

15.3 - Power Tools



www.tekform.com.au

>Router Bits

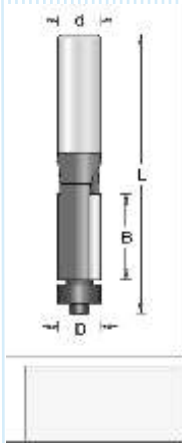

Stock Code	Description	Unit
WT60400	Flush Trimming Bit 12.7mm Dia x 20mm Cut Length x 1/4" Shank	Each
WT60401	Replacement Knives	Each

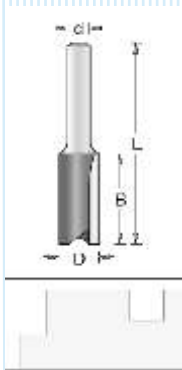

Stock Code	Description	Unit
WT60405	Straight Bit 12mm Dia x 23mm Cut Length x 1/4" Shank	Each
WT60406	Replacement Knives	Each

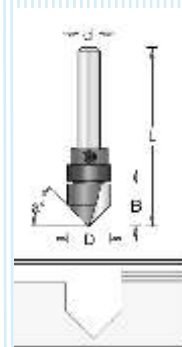

Stock Code	Description	Unit
WT60410	FV Grooving Bit 17.6mm Dia x 30mm Cut Length x 1/4" Shank	Each
WT60411	Replacement Knives	Each

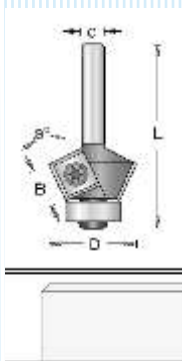

Stock Code	Description	Unit
WT60415	Bevel Trimming Bit 27.3mm Dia x 45° x 1/4" Shank	Each
WT60416	Replacement Knives	Each

www.tekform.com.au

> Router Bits

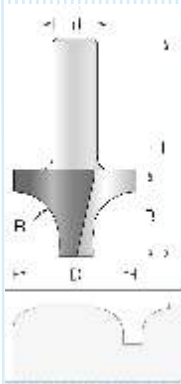

Stock Code	Description	Unit
WT60420	Rounding Over Bit 26mm Dia x 6mm Rad 1/4" Shank	Each
WT60421	Replacement Knives	Each

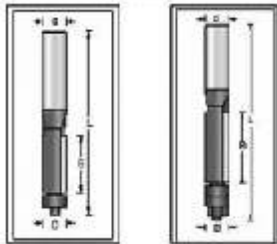

Stock Code	Description	Flutes	D	B	L	Dia	Unit
WT60500	Flush Trimmer Bit	2	6.35	25.4	67.0	6.35	Each
WT60501	Flush Trimmer Bit	2	12.7	25.4	67.0	6.35	Each
WT60502	Flush Trimmer Bit	2	12.7	38.1	98.0	12.7	Each
WT60503	Flush Trimmer Bit	2	12.7	51.0	116.7	12.7	Each

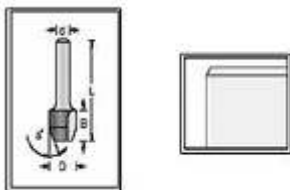

Stock Code	Description	Angle	D	B	L	Dia	Unit
WT60510	Combi Trimmer Bit - Flush & Bevel	23	9.5	12.7	41.3	6.35	Each
WT60511	Combi Trimmer Bit - Flush & Bevel	30	12.7	25.4	67.0	6.35	Each

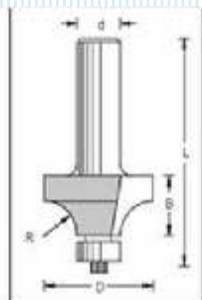

Stock Code	Description	Radius	D	B	L	Dia	Unit
WT60515	Rounding -Over Bit	6.35	25.4	12.7	51.0	6.35	Each
WT60516	Rounding -Over Bit	12.7	38.1	19.1	57.0	6.35	Each
WT60517	Rounding -Over Bit	9.5	31.8	15.9	57.0	12.7	Each
WT60518	Rounding -Over Bit	15.9	44.5	22.2	71.0	12.7	Each

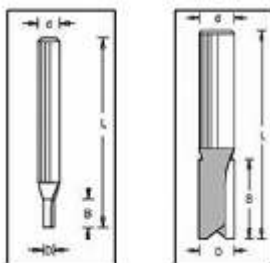



Stock Code	Description	D	B	L	Dia	Unit
WT60520	Straight Bit - Double Fluted	1/8"	7/16"	2"	1/4"	Each
WT60521	Straight Bit - Double Fluted	1/4"	1"	2 7/8"	1/4"	Each
WT60522	Straight Bit - Double Fluted	3/8"	1 1/4"	2 1/4"	1/4"	Each
WT60523	Straight Bit - Double Fluted	1/2"	2"	4 1/4"	1/2"	Each



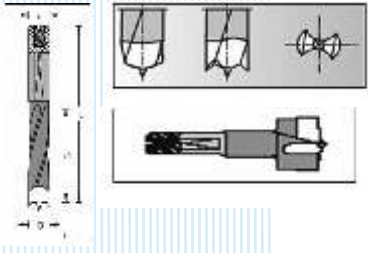

Stock Code	Description	Dia	D	Unit
WT60530	Click & Drill (Quick Change System) 3 Counter Sunks + 1 Chuck			Each
WT60531	Click & Drill (Quick Change System)	2.5"	9.5"	Each
WT60532	Click & Drill (Quick Change System)	3.2"	9.5"	Each
WT60533	Click & Drill (Quick Change System)	4.0"	9.5"	Each

> Drill Bits / Saw Blades / Accessories

	Stock Code	Description	D	L	Dia	Unit
	WT60540	Dowel Drills/Hinge Boring Bits R/H Black	5.0	57.5	10	Each
WT60541	Dowel Drills/Hinge Boring Bits L/H Orange	5.0	57.5	10	Each	
WT60546	Dowel Drills/Hinge Boring Bits R/H Black	8.0	57.5	10	Each	
WT60547	Dowel Drills/Hinge Boring Bits L/H Orange	8.0	57.5	10	Each	
WT60550	Dowel Drills/Hinge Boring Bits R/H Black	10.0	57.5	10	Each	
WT60551	Dowel Drills/Hinge Boring Bits L/H Orange	10.0	57.5	10	Each	
WT60560	Dowel Drills/Hinge Boring Bits R/H Black	35.0	57.5	10	Each	

	Stock Code	Description	Unit
WT80695	Mag Holder 1/4"	Each	

	Stock Code	Description	Unit
WT80600	Phillips Bit 25mm PH1	Each	
WT80605	Phillips Bit 25mm PH2	Each	
WT80625	Pozi Bit 25mm PZ2	Each	

	Stock Code	Description	Unit
WT80610	Phillips Bit 50mm PH1	Each	
WT80615	Phillips Bit 50mm PH2	Each	
WT80630	Pozi Bit 50mm PZ2	Each	

	Stock Code	Description	Unit
WT80675	Hex Bit 25mm x 3mm	Each	
WT80680	Hex Bit 25mm x 4mm	Each	
WT80685	Hex Bit 50mm x 3mm	Each	
WT80690	Hex Bit 50mm x 4mm	Each	
WT80692	Hex Bit 50mm x 5mm	Each	

www.tekform.com.au

> Drill Bits / Saw Blades / Accessories

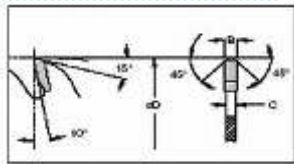

Stock Code	Description	Unit
WT60100	D-Max Saw Blades - Triple Chip 300mm Dia x 96 Teeth x 30mm Bore x 3.2kcrf	Each
WT60105	D-Max Saw Blades - Triple Chip 300mm Dia x 72 Teeth x 30mm Bore x 3.2kcrf	Each
WT60110	D-Max Saw Blades - Alternate Top Bevel 300mm Dia x 96 Teeth x 30mm Bore x 3.2kcrf	Each
WT60115	D-Max Saw Blades - Alternate Top Bevel 300mm Dia x 72 Teeth x 30mm Bore x 3.2kcrf	Each
WT60120	D-Max Saw Blades - Alternate Top Bevel 350mm Dia x 54 Teeth x 30mm Bore x 3.2kcrf	Each
WT60200	D-Max Saw Blades - NOVA - Split Scribes 120mm Dia x 2/12 Teeth x 20mm & 22mm Bore	Each
WT60205	D-Max Saw Blades - NOVA - Split Scribes 125mm Dia x 2/12 Teeth x 20mm & 22mm Bores	Each
WT60210	D-Max Saw Blades - NOVA - Split Scribes 125mm Dia x 2/12 Teeth x 50mm Bore - Altendorf	Each
WT60220	D-Max Saw Blades - NOVA - Split Scribes 125mm Dia x 2/12 Teeth x 20mm & 22mm Bore	Each

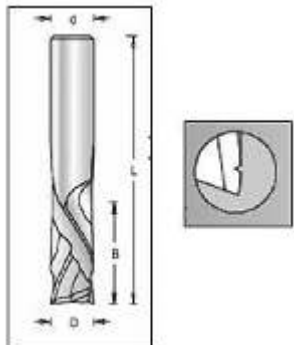

Stock Code	Description	Unit
WT60300	Vortex - Solid Carbide Compression Cutters (In 2 & 3 Flutes) 9.5mm Dia x 30mm Cut Length x 9.5mm Shank Z2	Each
WT60305	Vortex - Solid Carbide Compression Cutters (In 2 & 3 Flutes) 10mm Dia x 30mm Cut Length x 10mm Shank Z2	Each
WT60310	Vortex - Solid Carbide Compression Cutters (In 2 & 3 Flutes) 9.5mm Dia x 30mm Cut Length x 9.5mm Shank Z3	Each
WT60315	Vortex - Solid Carbide Compression Cutters (In 2 & 3 Flutes) 10mm Dia x 30mm Cut Length x 10mm Shank Z2	Each

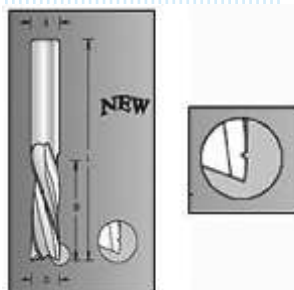





Stock Code	Description	Unit
WT60350	Solid Carbide Spiral Cutters (Up or Down Spiral) 8mm Dia x 22mm Cut Length x 8mm Shank Z2	Each
WT60355	Solid Carbide Spiral Cutters (Up or Down Spiral) 12.7mm Dia x 42mm Cut Length x 12.7mm Shank Z3	Each

> Drill Bits / Saw Blades / Accessories

	Stock Code	Description	Unit
	WT80027	Jigsaw Blade T101 B - 5 Pack To Suit Bosch, AEG, Makita, ELU Upward Cut, Fine	Each
			

	Stock Code	Description	Unit
	WT80028	Jigsaw Blade T101 BR - 5 Pack To Suit Bosch, AEG, Makita, ELU Downward Cut, Fine	Each
			

	Stock Code	Description	Unit
	WT80029	Jigsaw Blade T101 D - 5 Pack To Suit Bosch, AEG, Makita, ELU Upward Cut, Coarse	Each
			

	Stock Code	Description	Unit
	WT80036	Jigsaw Blade T144 D - 5 Pack To Suit Bosch, AEG, Makita, ELU Upward Cut, Coarse	Each
			
			

> Drill Bits / Saw Blades / Accessories

	Stock Code	Description	Unit
	WT80041	Makita Jigsaw Blade B10 - 5 Pack To Suit Bosch, AEG, Makita, ELU Upward Cut, Coarse	Each
			

	Stock Code	Description	Unit
	WT80011	Planer Blades Reversible - 2 Pack Cutting Width 82mm	Each

	Stock Code	Description	Unit
	WT30034	Repair Crayon Black	Each
	WT30037	Repair Crayon White	Each
	WT30038	Repair Crayon New Ant White	Each
	WT30039	Repair Crayon Baltic Pines	Each
	WT30040	Repair Crayon Birch	Each
	WT30041	Repair Crayon Cherry	Each
	WT30042	Repair Crayon Dark Walnut	Each
	WT30043	Repair Crayon Folkstone	Each
	WT30044	Repair Crayon Gunmetal	Each
	WT30045	Repair Crayon Ironstone	Each
	WT30046	Repair Crayon Jarrah	Each
	WT30047	Repair Crayon Light Teak	Each
	WT30048	Repair Crayon Marl Beige	Each
	WT30049	Repair Crayon Parchment	Each
	WT30050	Repair Crayon Red Cherry	Each
	WT30051	Repair Crayon Select Beech	Each
WT30052	Repair Crayon Teak	Each	
WT30053	Repair Crayon Tasmanian Oak	Each	
WT30054	Repair Crayon Wild Birch	Each	
WT30055	Repair Crayon Walnut	Each	
WT30056	Repair Crayon Young Beech	Each	

Drill Bits / Saw Blades / Accessories

www.tekform.com.au

> Drill Bits / Saw Blades / Accessories

	Stock Code	Description	Unit
	WT82380	Nuisance Dusk Mask	Each

	Stock Code	Description	Unit
	WT82382	P2 Respirators W/Value	Each

	Stock Code	Description	Unit
	WT82501	Muti 10 Pack	Each

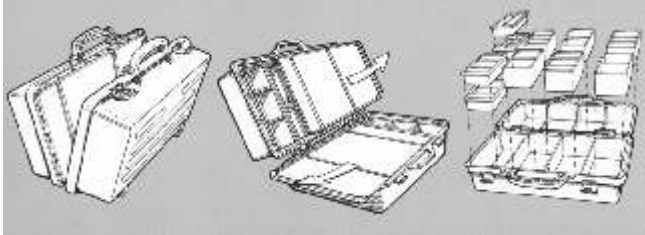

	Stock Code	Description	Unit
 <small>Made in Australia</small>	WT82500	Exactapak	Each

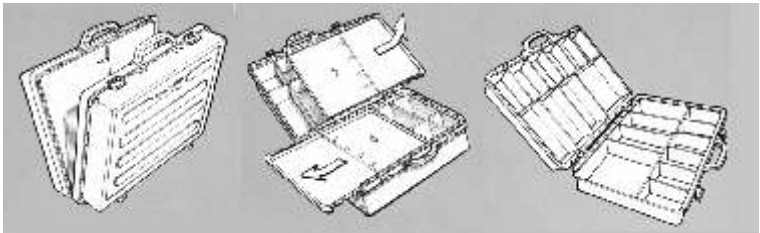





Drill Bits / Saw Blades / Accessories

>Power Tools

	Stock Code	Description	Unit
	BTD130RFE	14.4V 3.0H Mobile Impact Driver	Each
	<ul style="list-style-type: none"> • Makita built 4-pole motor design with dual steel ball bearings provides maximum torque • Hammer case cover protects work piece from scratches, increasing manoeuvrability • Built-in L.E.D light for more illuminated accurate work new bullet point • Ergonomically designed rubberised grip 		
	Stock Code	Description	Unit
	BTD140RFE	14.4V 3.0H Mobile Impact Driver	Each
	<ul style="list-style-type: none"> • Makita built 4-pole motor design with dual steel ball bearings provides maximum torque • 4 operation modes: drill (2 speed), screwdriver, percussion drill, impact driver • Hammer case cover protects work piece from scratches, increasing maneuverability • Built-in L.E.D light for more illuminated accurate work • Ergonomic design 		
	Stock Code	Description	Unit
	BDF441RFE	18V 3.0AH Mobile Impact Driver	Each
	<ul style="list-style-type: none"> • Makita built 4-pole motor design with dual steel ball bearings provides maximum torque • All metal 3-speed transmission • Mode selection system - quickly shift from "drill" to "driver" for increased efficiency • 13mm metal single sleeve ratcheting chuck • Built-in L.E.D light for more illuminated accurate work • Ergonomic design 		
	Stock Code	Description	Unit
	BDF451RFE	14.4V 3.0AH Mobile Driver Drill	Each
	<ul style="list-style-type: none"> • Makita built 4-pole motor design with dual steel ball bearings provides maximum torque • All metal 3-speed transmission • Mode selection system - quickly shift from "drill" to "driver" for increased efficiency • 13mm metal single sleeve ratcheting chuck • Built-in L.E.D light for more illuminated accurate work • Ergonomic design 		

> Power Tools

	Stock Code	Description	Unit
	6270DWLE	12V 1.3AH 10mm Mobile Driver Drill	Each
		<ul style="list-style-type: none"> • Compact design, balance, power and weight • Perfect for fitting door furniture, kitchen cupboard work and general fit out • Ergonomic and lightweight design for prolonged use • Variable speed • 10mm keyless chuck • Forward/reverse switch 	
	6280DWLE	14.4V 1.3AH 10mm Mobile Driver Drill	Each
		<ul style="list-style-type: none"> • Compact design, balance, power and weight • Perfect for fitting door furniture, kitchen cupboard work and general fit out • Ergonomic and lightweight design for prolonged use • Variable speed • 2 speed gearbox with 16 torque settings • 10mm keyless chuck • Rubber handle • Forward/reverse switch • Electric brake for accurate driving 	
	6339DWAE	14.4V 2AH 13mm Mobile Driver Drill	Each
		<ul style="list-style-type: none"> • 3 speed all metal planetary gearbox means you have a wider range of torque to speed ratios to select from • For those jobs where you need extra power – hole saws, auger bits and roofing screws • Metal Tech X3 gearbox also boasts an aluminium gear housing for greater durability • Replaceable carbon brushes extend motor life up to 5 times • 13mm single sleeve keyless chuck • Wrap around rubber handles for all day comfort and control • 16 torque settings • Variable speed and forward/reverse switch 	
	6349DWAE	18V 2.0AH 13mm Mobile Driver Drill	Each
		<ul style="list-style-type: none"> • 3 speed all metal planetary gearbox means you have a wider range of torque to speed ratios to select from • For those jobs where you need extra power – hole saws, auger bits and roofing screws • Metal Tech X3 gearbox also boasts an aluminium gear housing for greater durability • Replaceable carbon brushes extend motor life up to 5 times • 13mm single sleeve keyless chuck • Wrap around rubber handles for all day comfort and control • Variable speed and forward/reverse switch • Electric brake for accurate driving 	

> Power Tools



Stock Code	Description	Unit
8444DWAE	18V 2.0AH 13mm Mobile Driver Drill	Each

- Lightweight and power packed Impact Driver
- Inside you will find the amazing D-28 Makita Motor, a precision 2-piece unit, featuring rare earth magnets and replaceable armature for optimum power generation
- Metal Tech X3 gearbox also boasts an aluminium gear housing for greater durability
- Replaceable carbon brushes extend motor life up to 5 times
- 13mm single sleeve keyless chuck
- Wrap around rubber handles for all day comfort and control
- 16 torque settings
- Variable speed and forward/reverse switch



Stock Code	Description	Unit
6935FDWAE	14.4V 2.0AH Mobile Impact Driver	Each

- Lightweight and power packed Impact Driver
- Inside you will find the amazing D-28 Makita Motor, a precision 2-piece unit, featuring rare earth magnets and replaceable armature for optimum power generation
- Externally accessible replaceable carbon brushes
- Maklita located at the head of the tool will provide bright white light right into where you are working





Stock Code	Description	Unit
3709X	6.35mm (1/4") Laminate Trimmer	Each

- Ideal for trimming Laminates, edging, freehand and template design work
- See-through base plate for maximum visibility and control
- Rack & pinion fine depth adjustment
- Top mounted supply cord & power switch
- Rubberized "soft grip" for user comfort and control

	Stock Code	Description	Unit
	3612	12.7mm (1/2") Plunge Router	Each
<ul style="list-style-type: none"> • A tough, powerful and robust router • Handles anything from pine to red gum and iron bark replaceable armature for optimum power generation • Shaft lock for easy bit changes • 3-way preset plunge depth stop • Low noise (84db) • Optional dust extraction assembly (192035-6) 			

	Stock Code	Description	Unit
	3612C	12.7mm (1/2") Electronic Plunge Router	Each
<ul style="list-style-type: none"> • Dial up variable speed: 9,000–23,000rpm • Soft start feature for smoother start ups and electronic brake • Electronic speed control maintains constant speed even under load • Optional dust extraction assembly (192035-6) 			

	Stock Code	Description	Unit
	3601B	12.7mm (1/2") Router	Each
<ul style="list-style-type: none"> • Heavy duty machine with 1,050W motor for powerful routing, trimming, edging, beading and decorative work • D-handle design • Easy depth adjustment 			

	Stock Code	Description	Unit
	SP6000K	165mm Plunge Cut Circular Saw	Each
<ul style="list-style-type: none"> • Powerful 1,300W motor • Bevel range of -1 to 48 degrees • Electronic control - soft start, overload protector, constant speed and variable speed by dial for optimum cutting speed • Mechanical brake • Sawdust ejection backwards for comfortable operation - connectable to vacuum • Non-slip rubberised grip 			

> Power Tools

	Stock Code	Description	Unit
	5740NBSP	165mm Plunge Cut Circular Saw <ul style="list-style-type: none"> • Thin kerf blade cuts through all grades of timber even hardwoods • Improved handle design gives great balance • Bevel lock to 45° • Calibrated aluminium base for increased accuracy 	Each
	N5900B-2	235mm Circular Saw <ul style="list-style-type: none"> • Powerful 2,000W motor designed to handle all applications in soft and hardwoods • Repositioned fan vent, to blow the cutting line clean • Cutting window to give you a clear view of your line and blade • An excellent saw for ripping and crosscut, in everything from ply to hardwood 	Each
	B06030	150mm Random Orbital Sander <ul style="list-style-type: none"> • Efficient sander for all finishes with variable speed control • Through the pad dust extraction • Dual handle design for controlled operation; detachable front handle for sanding in confined areas • 3mm orbit diameter provides a swirl free finish • Connects directly to dust extraction system or dust bag • Very low vibration 	Each
	B05021KX1	125 mm Random Orbital Sander <ul style="list-style-type: none"> • Efficient sander for all finishes with variable speed control • Through the pad dust extraction • Dual handle design for controlled operation; detachable front handle for sanding in confined areas • 3mm orbit diameter provides a swirl free finish • Connects directly to dust extraction system or dust bag • Very low vibration 	Each

> Power Tools

	Stock Code	Description	Unit
	BO3700SP	1/3 Sheet Finishing Sander	Each
		<ul style="list-style-type: none"> • Ideal for coarse sanding of stock, through to fine finishing and preparation for paint or lacquer • Through the pad dust collection with removable dust bag or connect to dust extraction system • Improved base system reduces vibration 	

	Stock Code	Description	Unit
	BO4900V	1/2 Sheet Finishing Sander	Each
		<ul style="list-style-type: none"> • Through the pad dust control with paper waste bags or connect to dust extraction system • Dial up electronic variable speed control • Hook, loop base pad and clamps that suit all common papers • Reduced vibration for the operator with Makita's unique counter balancing system 	

	Stock Code	Description	Unit
	HP1620KSP	13mm Hammer Drill	Each
		<ul style="list-style-type: none"> • Compact and a powerful 650W motor for drilling into concrete, timber and steel • The reversing system ensures full power in both forward and reverse. The system also offers longer brush life and less wear and tear on the switch • Large trigger switch for easy operation • Ergonomic in-line design for control and comfort • Reversing switch is conveniently located • Side handle swivels 360° 	

	Stock Code	Description	Unit
	HP1621KSP	13mm Hammer Drill	Each
		<ul style="list-style-type: none"> • Compact and a powerful 650W motor for drilling into concrete, timber and steel • The reversing system ensures full power in both forward and reverse. The system also offers longer brush life and less wear and tear on the switch • Large trigger switch for easy operation • Ergonomic in-line design for control and comfort • Reversing switch is conveniently located • Side handle swivels 360° • Keyless chuck 	

www.tekform.com.au

> Power Tools

	Stock Code	Description	Unit
	HP2051	13mm 2 Speed Hammer Drill	Each
		<ul style="list-style-type: none"> • Ideal for coarse sanding of stock, through to fine finishing and preparation for paint or lacquer • Through the pad dust collection with removable dust bag or connect to dust extraction system • Improved base system reduces vibration 	

	Stock Code	Description	Unit
	9046	1/2 Sheet Orbital Sander	Each
		<ul style="list-style-type: none"> • Excellent for cleaning rough timber, removing paint or a final finish • Very low vibration • Through the pad dust extraction • Connects directly to a dust extraction system or dust bag • Rotatable front handle for added comfort • Hook, loop and clamps provided for paper installation 	

	Stock Code	Description	Unit
	1902SP	82mm Planer	Each
		<ul style="list-style-type: none"> • A sturdy, robust planer for all trade applications • Powerful 580W motor • Standard mini reversible TCT blades that provide a razor sharp long cutting life • Ergonomic in-line design for control and comfort • V-groove chamfering guide • 9mm fixed rebate capability 	

	Stock Code	Description	Unit
	N1900BK-2	82mm Planer	Each
		<ul style="list-style-type: none"> • Power to perform all applications from edging and chamfering to rebating • Standard mini reversible TCT blades that provide a razor sharp long cutting life • Ergonomic in-line design for control and comfort • V-groove chamfering guide • 9mm fixed rebate capability 	

www.tekform.com.au

> Power Tools



Stock Code	Description	Unit
MT190	Power Planer	Each

- Powerful 580W motor delivers performance
- A planing depth of 1mm V-groove chamfering guide
- Standard mini reversible TCT blades that provide a razor sharp long cutting life



Stock Code	Description	Unit
MT360	12.7mm (1/2") Plunge Router	Each

- 1,650W motor delivers tons of power for heavy duty professional routing applications
- A huge 60mm plunge depth
- Easily adjusted depth stop



Stock Code	Description	Unit
MT370	6.3mm (1/4) Trimmer	Each

- Powerful 530W
- Ideal for trimming laminates, edging, freehand and template design work
- Transparent base for a clear view of your work and cutting line for a perfect finish
- Robust and durable aluminium housing



Stock Code	Description	Unit
MT580	185mm Circular Saw	Each

- Powerful 1,050W motor takes on a range of timbers
- Flat rear side motor housing allows for easy blade changes
- Ergonomic handle design for comfort and control
- Front bevel lock to 45°

www.tekform.com.au

>Power Tools



Stock Code	Description	Unit
MT813K	13mm Hammer Drill	Each
	<ul style="list-style-type: none"> • Powerful 710W motor • Dust-proof washers protect the inside for longer tool life • Variable speed with forward/reverse • Lock on button for continuous use • 360° rotatable side handle 	



Stock Code	Description	Unit
MT940	100mm Belt Sander	Each
	<ul style="list-style-type: none"> • Powerful 940W • Unique design allowing for flush sanding to walls • Flat top design for upside down application • Industrial performance and durability at less expense • Forced dust extraction system • Double insulation 	



Stock Code	Description	Unit
MT064SK2	14.4V Mobile 10mm Driver Drill Kit	Each
	<ul style="list-style-type: none"> • Lightweight and compact drill with Mobile convenience • 19 clutch settings for accurate depth adjustment • Compact design allows you to get inside cupboards and tight spaces • Variable speed with forward/reverse • 10mm keyless chuck 	



Stock Code	Description	Unit
MT065SK2	18V Mobile 13mm Driver Drill Set	Each
	<ul style="list-style-type: none"> • Lightweight and compact drill with Mobile convenience • 19 clutch settings for accurate depth adjustment • Compact design allows you to get inside cupboards and tight spaces • Variable speed with forward/reverse • 13mm keyless chuck 	

WOOD TOOLS

Group 15
15.3